

Drivelock 40 Bushes

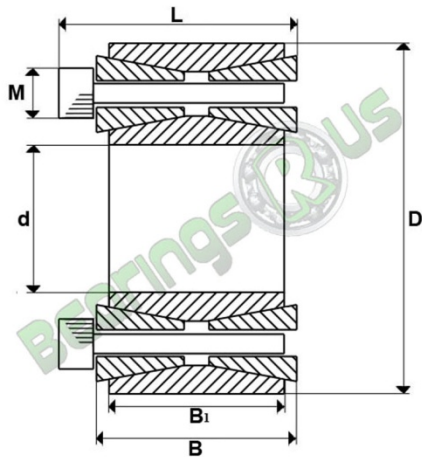

Drivelock 40 Bushes are a non self centering keyless shaft-hub locking devices. They are quick to install & can be easily adjusted or moved into mounting position. These units are most commonly used on applications in general engineering to transmit high torques and axial loads utilizing larger machining tolerances.

- Not self centering
- Medium high torques 290 to 45810 Nm
- Bores 19 to 190mm

DRIVELOCK 40									
d (h8) (mm)	D (mm)	B (mm)	L (mm)	M	Ts Nm	T Nm	F kN	p N/mm2	
19	47	20	28	M6	15	290	26	90	
20	47	20	28	M6	15	295	26	90	
22	47	20	28	M6	15	320	26	89	
24	50	20	28	M6	15	370	30	94	
25	47	26	32	M6	16.5	304	22	78	
25	50	20	28	M6	15	390	30	94	
28	55	20	28	M6	15	490	30	94	
30	55	20	28	M6	15	520	34	94	
32	60	20	28	M6	15	680	40	105	
35	60	20	28	M6	15	710	40	105	
38	65	20	28	M6	15	880	44	108	
40	65	20	28	M6	15	930	45	108	
42	75	24	34	M8	37	1580	71	123	
45	75	24	34	M8	37	1620	71	123	
48	80	24	34	M8	37	1690	71	108	
50	80	24	34	M8	37	1770	71	113	
55	85	24	34	M8	37	2260	83	127	
60	90	24	34	M8	37	2470	83	120	
65	95	24	34	M8	37	3040	92	128	
70	110	28	40	M10	70	4560	130	127	
75	115	28	40	M10	70	4820	130	124	
80	120	28	40	M10	70	5130	130	120	
85	125	28	40	M10	70	6230	144	127	
90	130	28	40	M10	70	6520	144	122	
95	135	28	40	M10	70	7770	164	133	
100	145	33	47	M12	127	9460	189	133	
110	155	33	47	M12	127	10490	189	122	
120	165	33	47	M12	127	12945	214	133	
130	180	38	52	M12	127	17360	268	113	
140	190	38	52	M12	127	20650	292	123	
150	200	38	52	M12	127	23815	318	122	
160	210	38	52	M12	127	27615	346	127	
170	225	44	60	M14	195	32370	379	118	
180	235	44	60	M14	195	37270	416	123	
190	250	52	68	M14	195	45810	488	113	

Glossary		Machining Data			
Ts (Nm)	Screw/bolt tightening torque	Recommended shaft & hub tolerances for full torque transmission are :			
T (Nm)	Torque transmissible with tightening torque	All shafts	h8 except	All hubs	H8
F (kN)	transmissible with tightening torque	DL40 shaft	h9	DL40 hub	H9
P (N/mm2)	Hub/shaft surface pressure	DL50* shaft	h6	DL50* hub	H7
* DL50 < 40mm diam.					

Tel: 0845 850 0208
 Web: www.bearingsrus.co.uk

